

B-1708 push to close latch knob latch

IP40

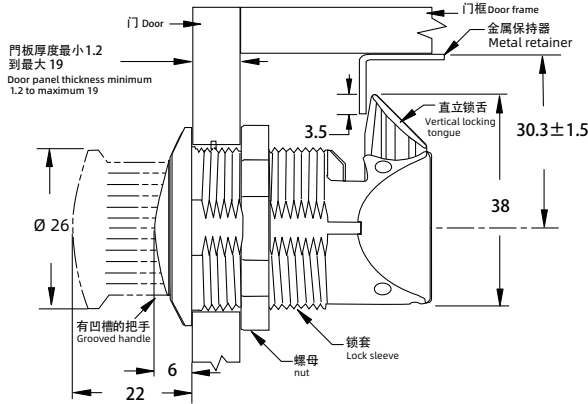

关闭 close

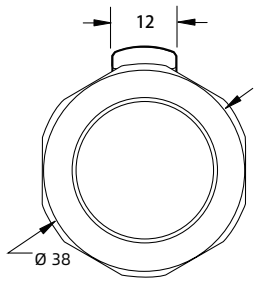
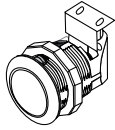

按压弹出按钮
Press the eject button

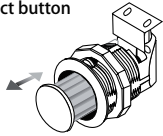

转动按钮开启
Turn button on

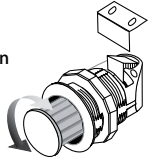

保持器 holder

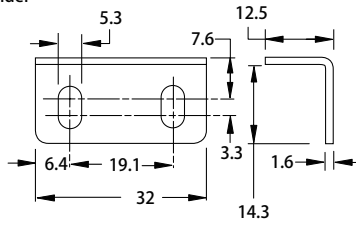

安装 install

Ø 8.4 ± 0.2
可选择的用于校准柱的孔
Optional holes for calibrating columns

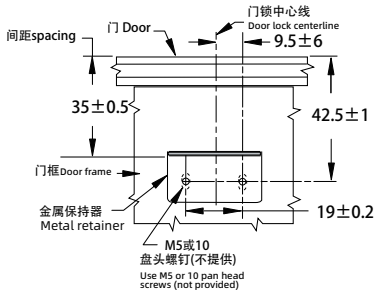
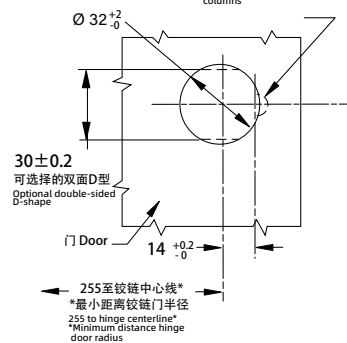

1. Material and surface treatment:
Lock body, handle, holder : PC+ABS

2. Performance parameters:
Protection class: IP40
Maximum working load: 310N
Working temperature range: -30 to 60 °C
Flame retardant grade: UL94-HB

1. 材质及表面处理:
锁体, 手柄, 保持器: PC+ABS

2. 性能参数:
防护等级: IP40
最大工作载荷: 310N
工作温度范围: -30°C到60°C
阻燃等级: UL94-HB

如需获得产品 3D 模型图, 请联系 WWW.FORND.COM

铬 Bright chrom	黑色 Black	金色 Golden
B-1708-30	B-1708-40	B-1708-35