

## C3-1527

## compression cam latch

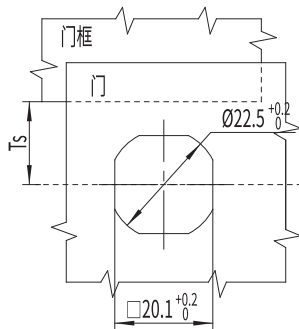

### 锁芯 Cylinder

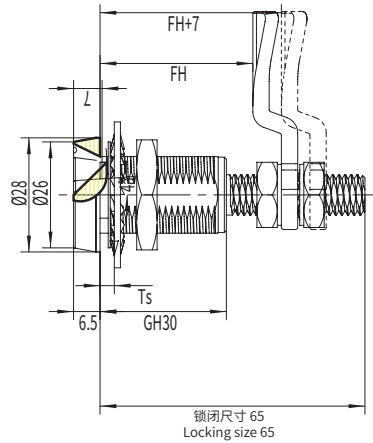
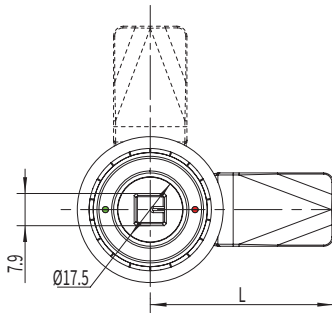

### 选型 Model selection

锁芯选型  
Lock cylinder selection

**C3-1527-SX-LH-A1L**

L 代表左锁 顺时针旋转锁紧  
L represents clockwise rotation and locking of the left lock  
R 代表右锁 逆时针旋转锁紧  
R represents the counterclockwise rotation and locking of the right lock

L 代表钢柱长度  
L represents the length of the steel bolt  
H 代表有效高度  
H represents effective height

### 旋转 Rotate

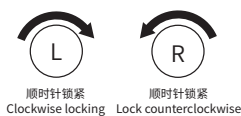

1. Material and surface treatment:  
Main body, Steel bolt: SUS304 or SUS316  
Sealing ring: EPDM foam.

2. Performance parameters:  
Protection class: IP65  
Unlocking torque:  $\leq 0.79\text{N}\cdot\text{M}$   
Ultimate load: 700N  
Tensioning and stretching amount: 7mm

3. Installation instructions:  
Fixed screw torque 10N·M  
Fixed nut torque 17N·M  
Applicable door panel thickness: 1-15mm

1. 材质及表面处理:  
主体, 钢栓: SUS304 或 SUS316  
密封圈: EPDM发泡胶。

2. 性能参数:  
防护等级: IP65  
解锁扭矩: 小于等于 0.79N·M  
极限载荷: 700N  
拉紧伸缩量: 7mm

3. 安装说明:  
固定螺丝扭矩 10N·M  
固定螺母扭矩 17N·M  
适用门板厚度: 1-15mm

如需获得产品 3D 模型图，请联系 WWW.FORND.COM