

连杆型旋转把手 Rod Control Swinghandle

A-1211 Rod Control Swinghandle

RL

IP65

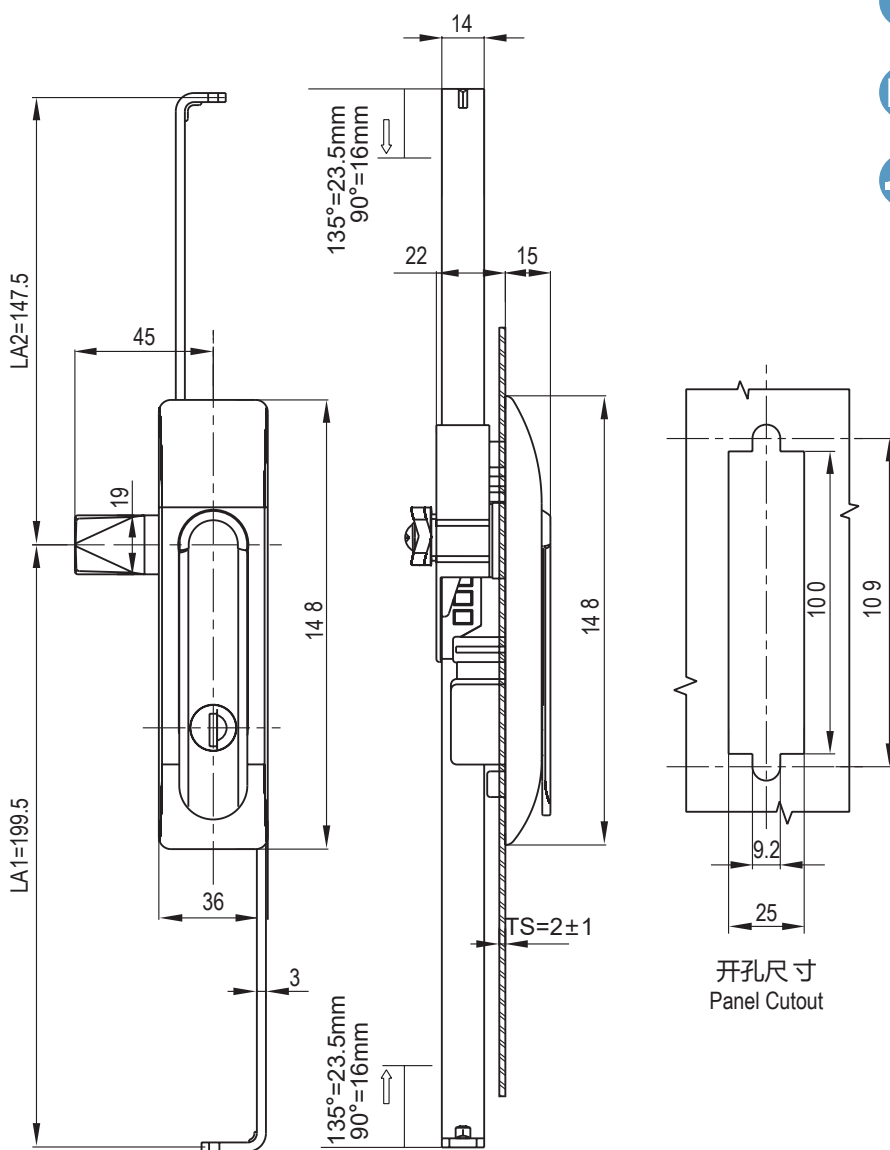

开孔尺寸
Panel Cutout



1. Material and surface treatment:
Lock body: PA66+30%GF or Zinc alloy
handle, dust cover : Zamak DIN-EN 1774-ZnAl4Cu1
Steel bolt: iron galvanized
Sealing ring: EPDM foam.

2. Performance parameters:
Protection class: IP65
Handle bearing tension value: ≤ 195N
Handle bearing torque value: ≤ 10N. m

3. Remark:
Key different on request
CH751 key code on request
Default keyed K333

1. 材质及表面处理:
锁体: PA66+30%GF或锌合金
手柄, 防尘盖: 5#锌合金喷塑黑
钢栓: 铁镀锌
密封圈: EPDM发泡胶。

2. 性能参数:
防护等级: IP65
手柄承载拉力值: ≤195N
手柄承载扭矩值: ≤10N.m

3. 备注:
专用钥匙可选
CH751 钥匙可选
默认K333钥匙

锁芯 Cylinder style	全锌合金 Zinc Die		锌合金手柄, 塑料锁壳 Zinc die handle, PA lock housing	
	Version B(两点拉杆型 2Prod control)	Version C(三点拉杆型 3Prod control)	Version B(两点拉杆型 2Prod control)	Version C(三点拉杆型 3Prod control)
圆柱 K333 相同钥匙 Alike K333 Round Cylinder	A-1211-2001-40	A-1211-3001-40	A-1211-2001-64	A-1211-3001-64