

Swing handle lock

A-1234



RL

IP65

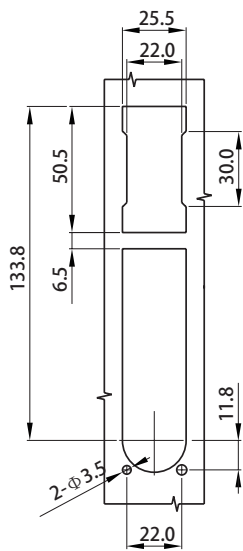
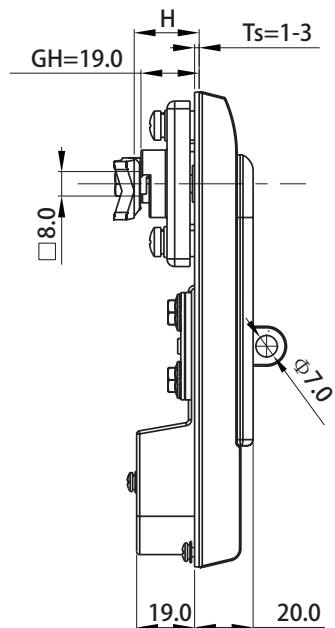
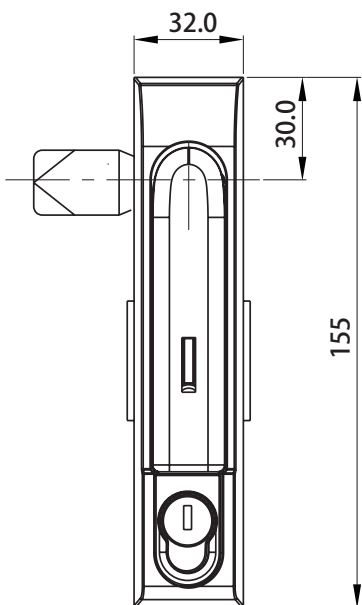

开孔尺寸
Panel cutout

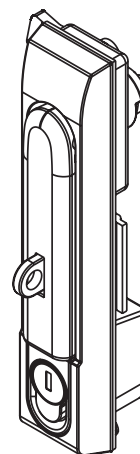

如 需 获 得 产 品 3 D 模 型 图 ， 请 联 系 W W W . F O R N D . C O M

1. Material and surface treatment:
Lock body, handle, dust cover : Zamak
DIN-EN 1774-ZnAl4Cu1
Steel bolt: iron galvanized
Sealing ring: EPDM foam.

2. Performance parameters:
Protection class: IP65
Handle bearing tension value: $\leq 225\text{N}$
Handle bearing torque value: $\leq 20\text{N}\cdot\text{m}$
Maximum static load: 270N

3. Remark:
Padlockable on request
Interchangeable profile cylinder Padlockable on request

1. 材质及表面处理:
锁体, 手柄, 防尘盖 5# 锌合金喷塑黑
钢栓: 铁镀锌
密封圈: EPDM发泡胶

2. 性能参数: 防护等级: IP65
手柄承载拉力值: $\leq 225\text{N}$
手柄承载扭矩值: $\leq 20\text{N}\cdot\text{m}$
最大静载荷: 270N

3. 备注:
可配挂锁
锁头可换

	Version A (锁舌型 Cam control)	
	不带挂 Without padlock	带挂 Padlockable
喷塑黑 Black Powder Coated	A-1234-1001-40	A-1234-1011-40
纳米喷漆 (银亚光) NM spray painting (matte silver)	A-1234-1001-50	A-1234-2011-50