

A-1205

Rod Control Swinghandle

RL

IP65

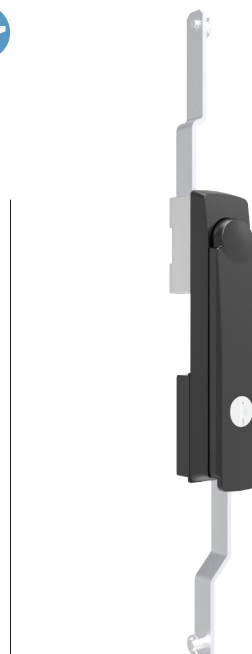
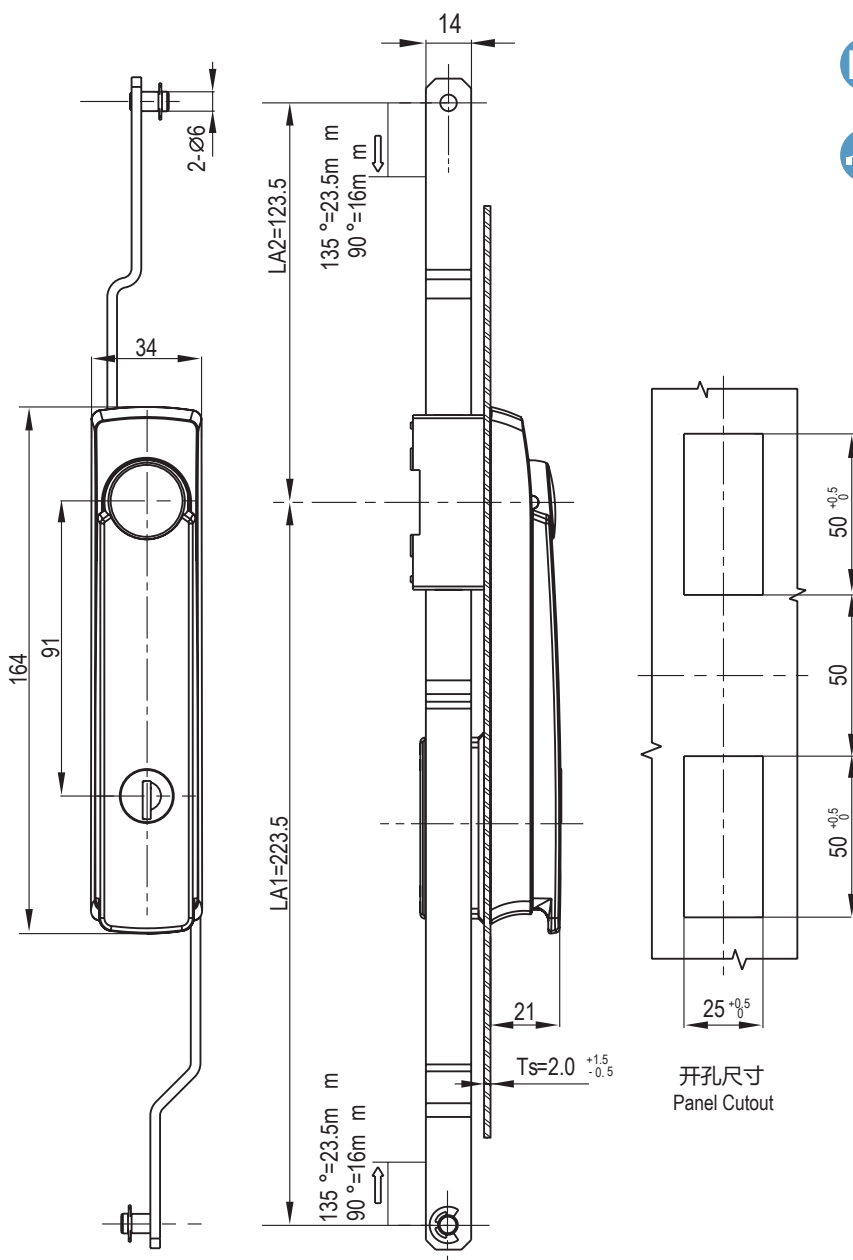

1. Material and surface treatment:
Lock body: PA66+30%GF;
handle: Zamak DIN-EN 1774-ZnAl40Cu1
Steel bolt: iron galvanized
Sealing ring: EPDM foam.

2. Performance parameters:
Protection class: IP65
Handle bearing tension value: ≤ 235N
Handle bearing torque value: ≤ 40N.m
Maximum static load: 270N

3. Remarks:
Optional dedicated key
CH751 key optional
Default K333 key

1. 材质及表面处理:
锁体: PA66+30%GF
手柄: 5# 锌合金喷塑黑
钢栓: 铁镀锌
密封圈: EPDM发泡胶。

2. 性能参数:
防护等级: IP65
手柄承载拉力值: ≤ 235N
手柄承载扭矩值: ≤ 40N.m
最大静载荷: 270N

3. 备注:
专用钥匙可选
CH751 钥匙可选
默认K333钥匙

锁芯 Cylinder style	Version B(两点拉杆型 2Prod control)	Version C(三点拉杆型 3Prod control)
半圆柱 K333 相同钥匙 Alike K333 ProPle Round Cylinder	A-1205-2001-64	A-1205-3001-64