

lever compression latch

A-1444

IP40

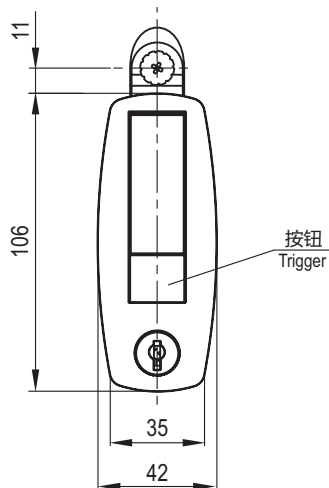
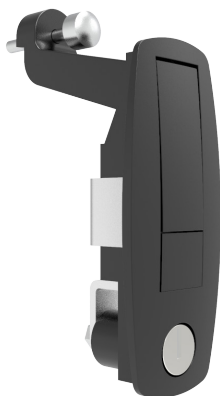

带锁芯
Key locking

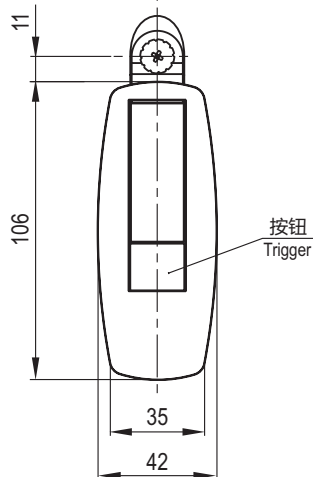

无锁芯
Non-locking

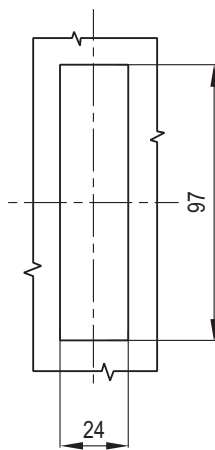
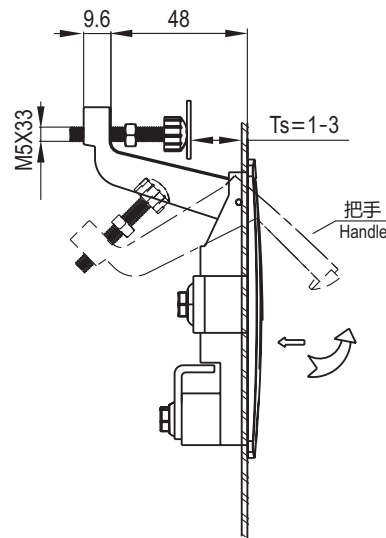

如需获得产品3D模型图，请联系 WWW.FORND.COM

1. Material and surface treatment:
Lock body, handle: Zamak DIN-EN 1774-ZnAl4Cu1
Steel bolt: iron galvanized
Sealing ring: EPDM foam.

2. Performance parameters:
Protection class: IP40
Handle bearing tension value: $\leq 750\text{N}$
Maximum static load: 200N

3. Remark:
Default CH751 key code

1. 材质及表面处理:
锁体, 手柄: 5# 锌合金
钢栓: 铁镀锌
密封圈: EPDM 发泡胶。

2. 性能参数:
防护等级: IP40
手柄承载拉力值: $\leq 750\text{N}$
最大静载荷: 200N

3. 备注:
默认 CH751 钥匙

喷塑亚光黑 Black powder coated		亮铬 Bright Chrome	
不带锁芯型 Non-locking	CH751 locking with shutter	不带锁芯型 Non-locking	CH751 locking with shutter
A-1444-100-40	A-1444-110-40	A-1444-100-30	A-1444-110-30