

Rod Control Swinghandle

A-1209



RL

IP65

NEW

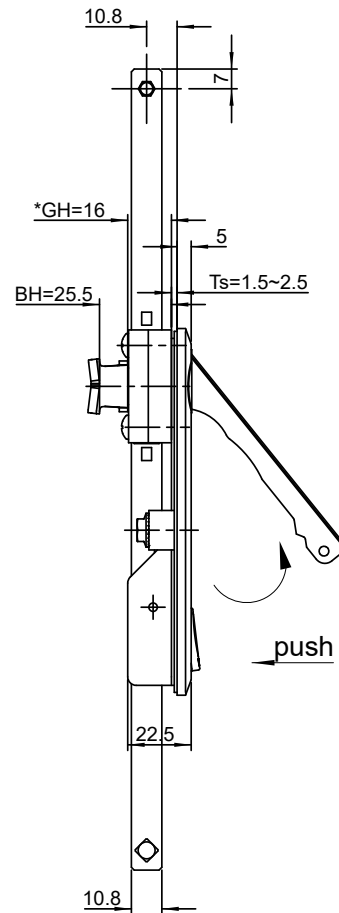
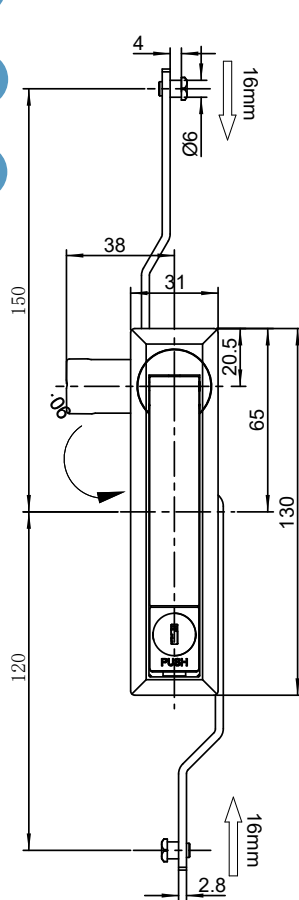

开孔尺寸
Cut out

注：调换传动条，钢栓左右位置，实现左右开启
Note: Change the drive bar and the left and right positions of the steel bolt to realize the left and right opening

如 需 获 得 产 品 3 D 模 型 图 ， 请 联 系 W W W . F O R N D . C O M

1. Material and surface treatment:
Lock body, handle, dust cover : Zamak
DIN-EN 1774-ZnAl4Cu1
Steel bolt: iron galvanized
Sealing ring: EPDM foam.

2. Performance parameters: Protection class: IP65

3. Remark:
Padlockable on request
Default K333 key

1. 材质及表面处理:
锁体, 手柄, 防尘盖 5#锌合金喷塑黑
钢栓: 铁镀锌
密封圈: EPDM发泡胶。

2. 性能参数: 防护等级: IP65

3. 备注:
可配挂锁
默认K333钥匙

Version B (两点拉杆型 2Prood control)		Version C (三点拉杆型 3Prood control)	
亚光漆 Matt Pnish paint	喷塑亚光黑 Black powder coated	亚光漆 Matt Pnish paint	喷塑亚光黑 Black powder coated
A-1209-2001-50	A-1209-2001-40	A-1209-3001-50	A-1209-3001-40