

Heavy Duty Lift & Turn Compression Latches

**A-1548**

IP65

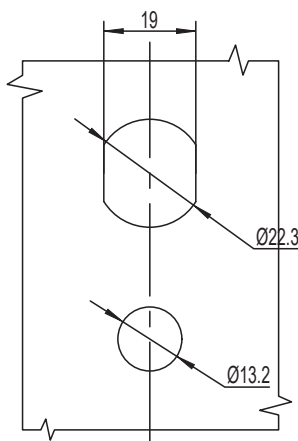
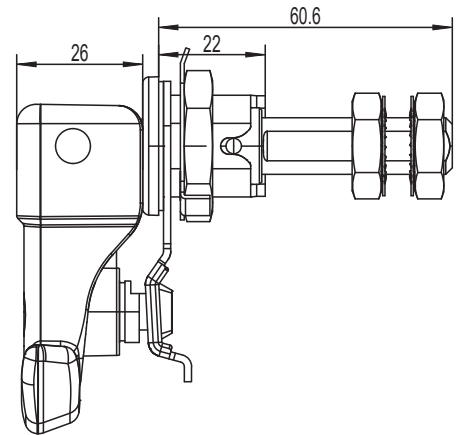
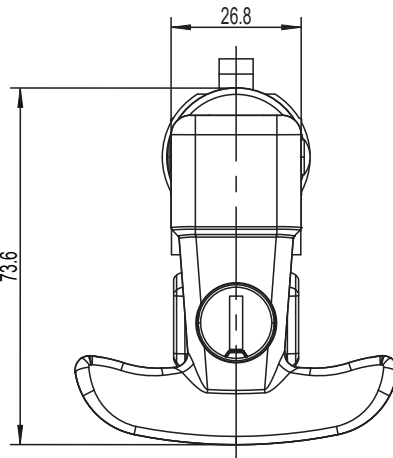

开孔尺寸

如需获得产品3D模型图，请联系 WWW.FORND.COM

1. Material and surface treatment:  
Lock body, handle: Zamak DIN-EN  
1774-ZnAl4Cu1 or SUS304  
Steel bolt: iron galvanized  
Sealing ring: EPDM foam.

2. Performance parameters:  
Protection class: IP65  
Compression force: 6.4mm  
Maximum static load: 1000N

3. Remark:  
Default CH751 key code

1. 材质及表面处理:  
锁体, 手柄: 5# 锌合金 或 SUS304  
钢栓: 铁镀锌  
密封圈: EPDM 发泡胶。

2. 性能参数:  
防护等级: IP65  
压紧力: 6.4mm  
最大静载荷: 1000N

3. 备注:  
默认 CH751 钥匙

间距 Grip Range		锌合金 Zinc alloy		SUS304	
最小 MIN	最大 MAX	CH751 钥匙锁定 CH751 keylocking	不带钥匙锁 Non-locking	CH751 钥匙锁定 CH751 keylocking	不带钥匙锁 Non-locking
28	43	A-1548-1010-40	A-1548-2010-40	A-1548-1010-A1	A-1548-2010-A1
43	58	A-1548-1020-40	A-1548-2020-40	A-1548-1020-A1	A-1548-2020-A1
58	73	A-1548-1047-40	A-1548-2047-40	A-1548-1047-A1	A-1548-2047-A1
73	88	A-1548-1040-40	A-1548-2040-40	A-1548-1040-A1	A-1548-2040-A1
88	104	A-1548-1050-40	A-1548-2050-40	A-1548-1050-A1	A-1548-2050-A1