

A-1556 lift & turn compression latch

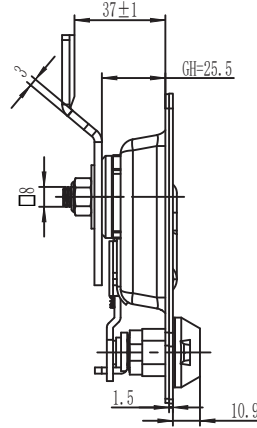

IP54

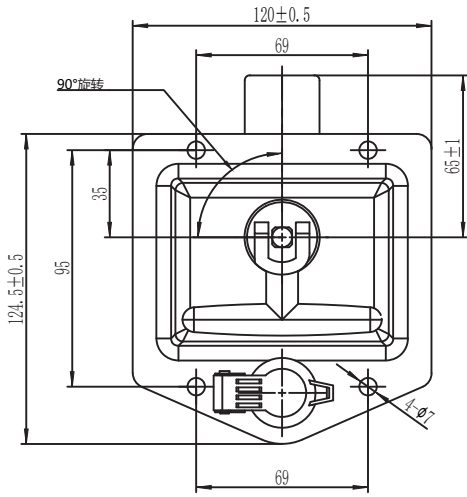
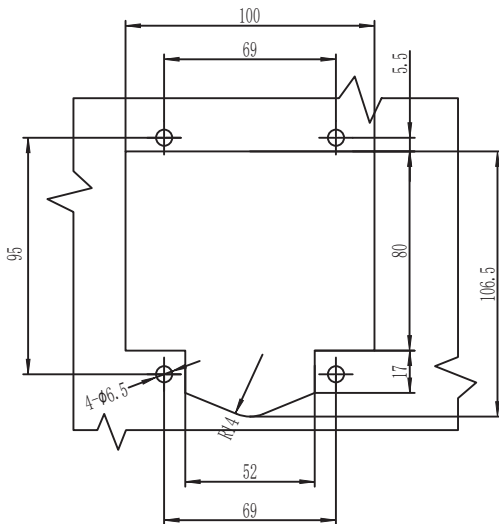
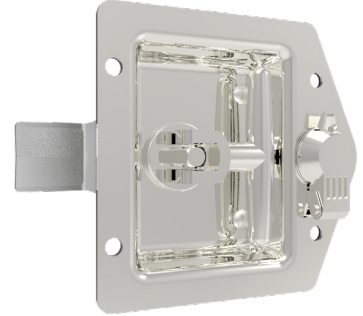

开孔尺寸
Cut out

1. Material and surface treatment:
Lock body, handle: SUS304
Steel bolt: iron galvanized
Sealing ring: EPDM foam.

2. Performance parameters:
Protection class: IP54
Handle carrying torque value $\leq 14\text{N}\cdot\text{m}$
Steel bolt bearing capacity $\leq 510\text{N}$

3. Remark:
Default K130 key code

1. 材质及表面处理:
锁体, 手柄: SUS304
钢栓: 铁镀锌
密封圈: EPDM发泡胶。

2. 性能参数:
防护等级: IP54
手柄承载扭矩值 $\leq 14\text{N}\cdot\text{m}$
钢栓承载力 $\leq 510\text{N}$

3. 备注:
默认 K130 钥匙

如需获得产品 3D 模型图，请联系 WWW.FORND.COM