

B-1110

T handle lock

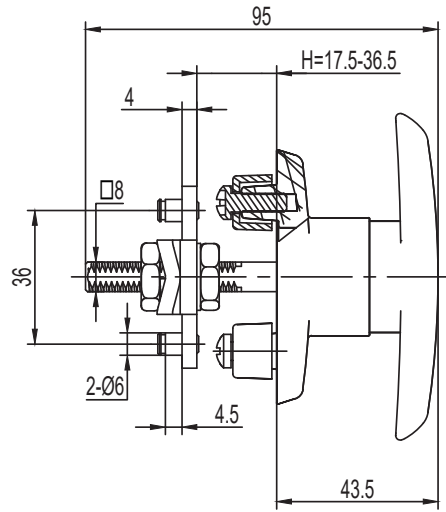
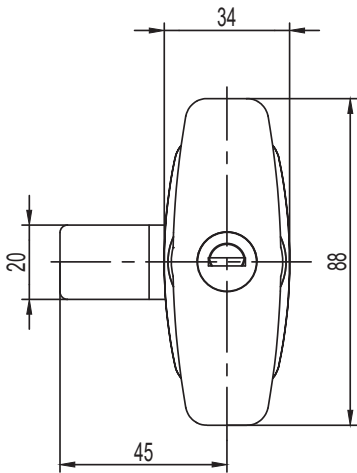

IP40

RL

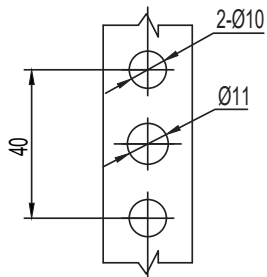

开孔尺寸Cut out

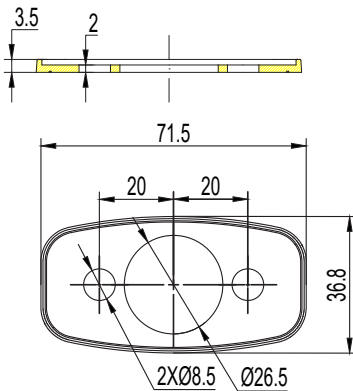

1. Material and surface treatment:
Lock body, handle: PA66+30%GF
Steel bolt: iron galvanized

2. Performance parameters:
Protection class: IP40

3. Remarks:
Optional dedicated key
Default K120 key
Optional EPDM rubber pad

1. 材质及表面处理:
锁体, 手柄: PA66+30%GF
钢栓: 铁镀锌

2. 性能参数: 防护等级: IP40

3. 备注:
专用钥匙可选
默认 K160 钥匙
EPDM的橡胶垫可选

尼龙, 黑色 PA66+30GF Black	
左向 lift	B-1110-L-60
右向 right	B-1110-R-60