

F-1001

Seal handle

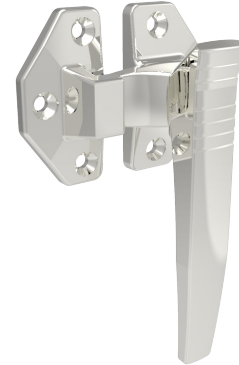
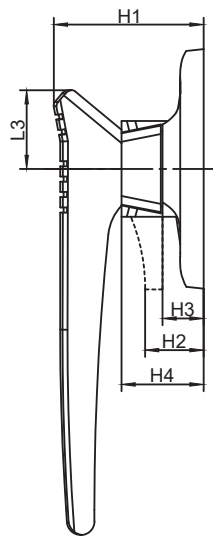
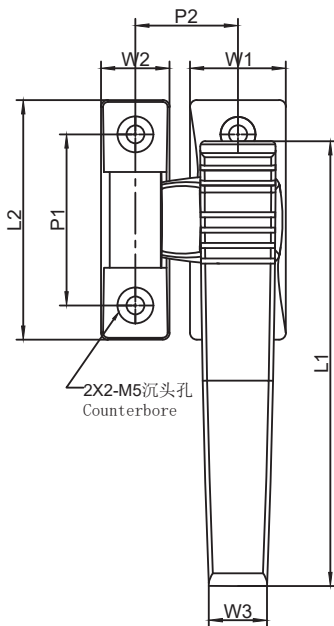
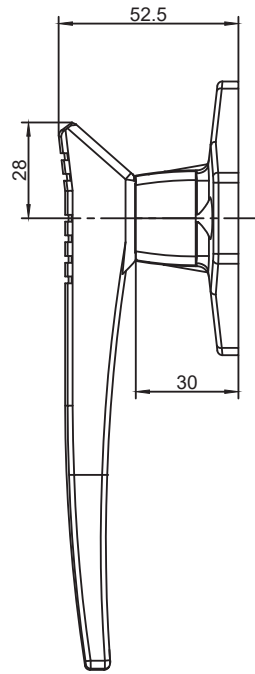
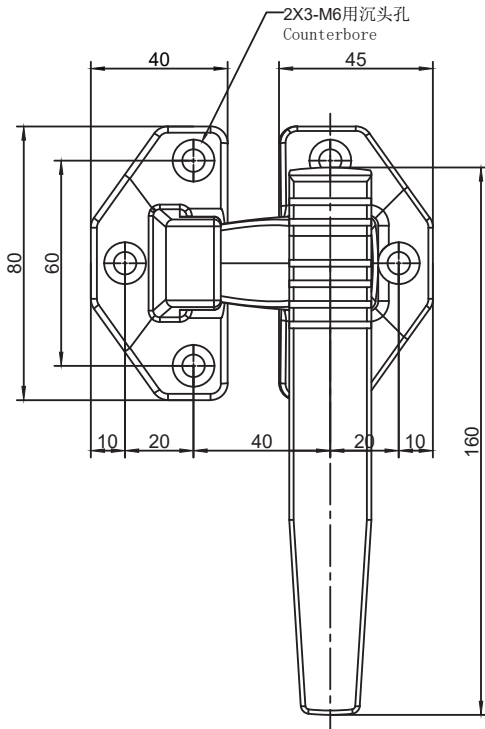

产品编号 Product number		L1	L2	L3	W1	W2	W3	H1	H2	H3	H4	P1	P2
SUS304	亮铬 Bright Chrome												
F-1001-1-A1	F-1001-1-30	参照图纸 Refer to the drawing											
F-1001-2-A2	F-1001-2-30	130	70	23	28	20	17	44	18	12.5	24	50	30
F-1001-3-A3	F-1001-3-30	105	54	18	23	16	13	32	17.5	10.5	23	40	25

1. Material and surface treatment:
Main body: Zamak DIN-EN 1774-ZnAl4Cu1
or SUS304

1. 材质及表面处理:
主体: 5#锌合金 或 SUS304

如需获得产品 3D 模型图，请联系 WWW.FORND.COM