

Screw-on Torque Hinge

H1-2426

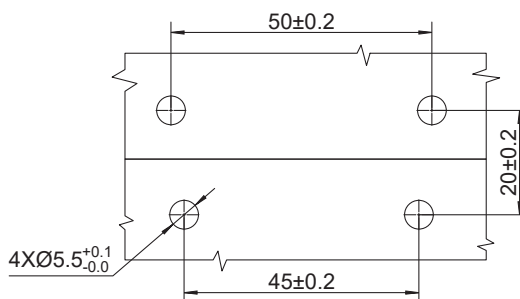
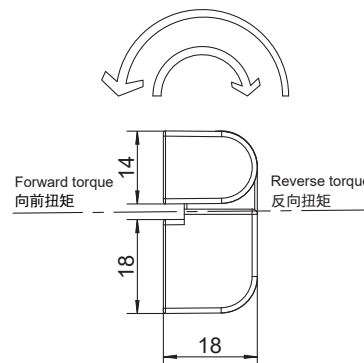
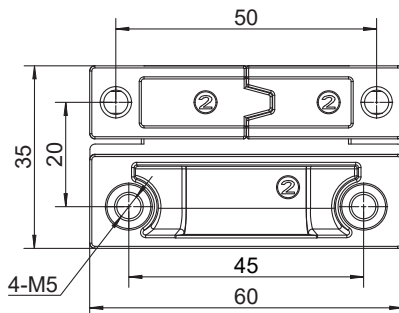

如需获得产品3D模型图，请联系 WWW.FORND.COM

1. Material and surface treatment:
Main body : Zamak DIN-EN 1774-ZnAl4Cu1
or SUS304

1. 材质及表面处理:
主体: 5#锌合金 或 SUS304

对称扭矩 N. m Symmetric N. m			
喷塑黑 Black Powder Coated	亮铬 Bright Chrome	SUS304	对称扭矩 Symmetrical Torque
H1-2326-18-40	H1-2326-18-30	H1-2326-18-A1	1.8
H1-2326-23-40	H1-2326-23-30	H1-2326-23-A1	2.3
H1-2326-34-40	H1-2326-34-30	H1-2326-34-A1	3.4
H1-2326-45-40	H1-2326-45-30	H1-2326-45-A1	4.5
H1-2326-60-40	H1-2326-60-30	H1-2326-60-A1	6.0

不对称扭矩 N. m Asymmetric N. m				
喷塑黑 Black Powder Coated	亮铬 Bright Chrome	SUS304	向前扭矩 N. m Forward Torque N. m	反向扭矩 N. m Reverse Torque N. m
H1-2326-2314F-40	H1-2326-2314F-30	H1-2326-2314F-A1	2.3	1.4
H1-2326-3420F-40	H1-2326-3420F-30	H1-2326-3420F-A1	3.4	2.0
H1-2326-4527F-40	H1-2326-4527F-30	H1-2326-4527F-A1	4.5	2.7
H1-2326-6036F-40	H1-2326-6036F-30	H1-2326-6036F-A1	6.0	3.6
H1-2326-1423R-40	H1-2326-1423R-30	H1-2326-1423R-A1	1.4	2.3
H1-2326-2034R-40	H1-2326-2034R-30	H1-2326-2034R-A1	2.0	3.4
H1-2326-2745R-40	H1-2326-2745R-30	H1-2326-2745R-A1	2.7	4.5
H1-2326-3660R-40	H1-2326-3660R-30	H1-2326-3660R-A1	3.6	6.0